

THIS DRAWING IS UNPUBLISHED. RELEASED FOR PUBLICATION  
 © COPYRIGHT BY TYCO ELECTRONICS CORPORATION. ALL RIGHTS RESERVED.

LOC	DIST	REVISIONS					
GP	00	P	LTR	DESCRIPTION	DATE	DWN	APVD
		N		REVISED PER ECO-08-005709	18FEB08	JDP	CWR

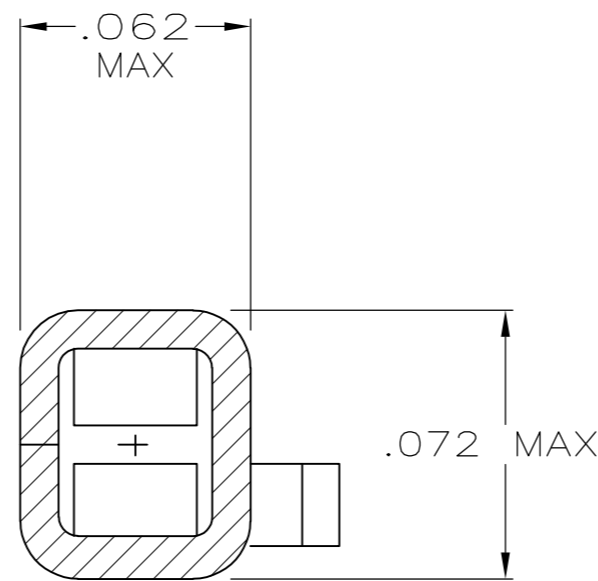

SECTION A-A  
SCALE 20:1

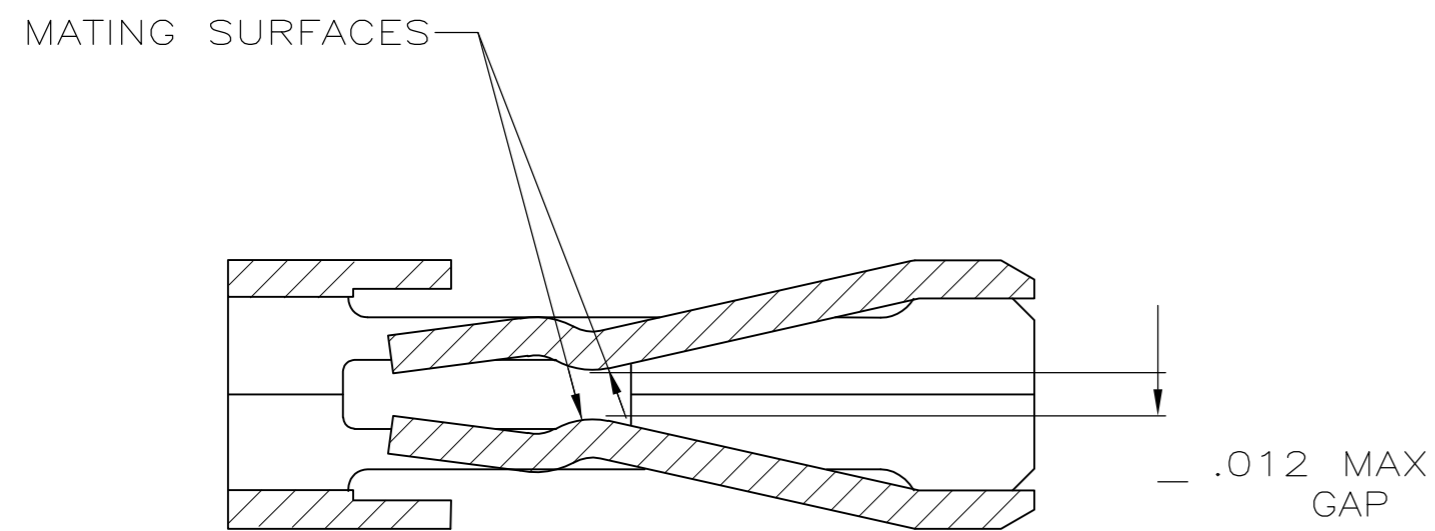
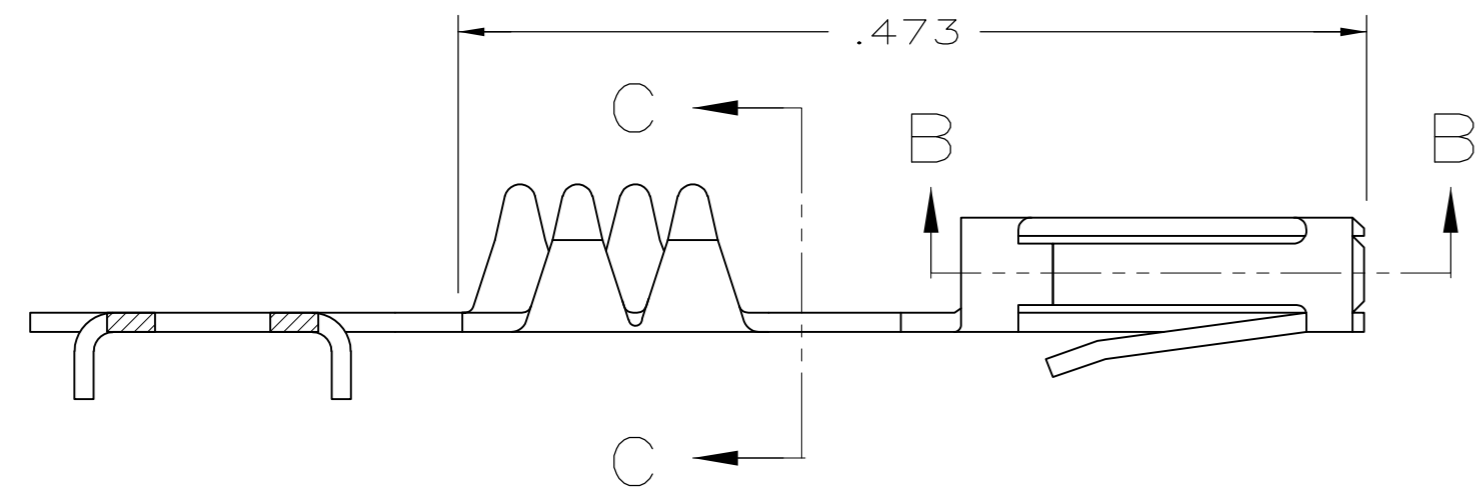
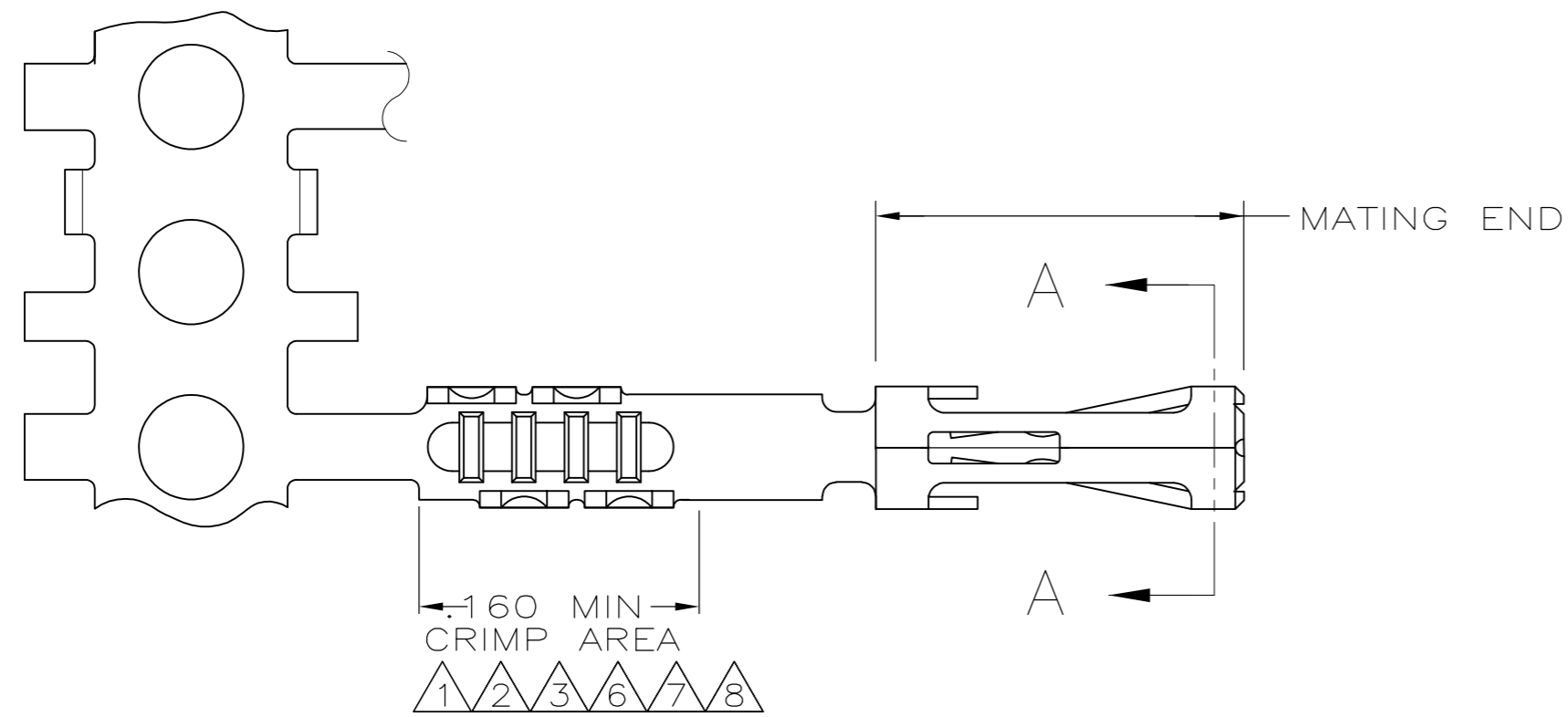
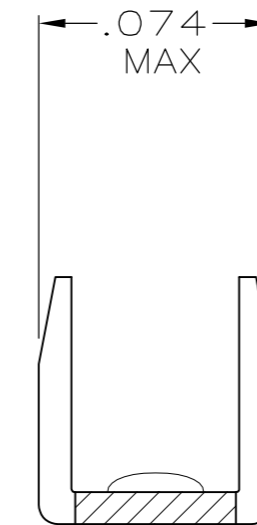

SECTION C-C  
SCALE 20:1

- ① PREPLATED .000050 MIN THK NICKEL OVER ENTIRE CONTACT WITH .000015 MIN THK GOLD ON THE MATING SURFACES AND PLATED WITH .000100 MIN THK BRIGHT TIN/LEAD IN CRIMP AREA.
- ② PREPLATED .000050 MIN THK NICKEL OVER ENTIRE CONTACT WITH .000030 MIN THK GOLD ON THE MATING SURFACES AND PLATED WITH .000100 MIN THK BRIGHT TIN/LEAD IN CRIMP AREA.
- ③ PREPLATED .000050 MIN THK NICKEL OVER ENTIRE CONTACT WITH .000050 MIN THK GOLD ON THE MATING SURFACES AND PLATED WITH .000100 MIN THK BRIGHT TIN/LEAD IN CRIMP AREA.
- ④ .000100 MIN THK BRIGHT TIN/LEAD OVER .000050 MIN THK NICKEL OVER ENTIRE CONTACT.
- 5. MATING POST LENGTH ACCEPTED:  
SINGLE ROW HOUSINGS .210-.323  
DOUBLE ROW HOUSINGS .225-.323
- ⑥ GOLD FLASH IN CRIMP AREA, .000100 MIN TIN ON THE MATING END, BOTH OVER .000050 MIN NICKEL.
- ⑦ PREPLATED .000050 MIN THK NICKEL OVER ENTIRE CONTACT WITH .000015 MIN THK GOLD ON THE MATING SURFACES, AND PLATED WITH GOLD FLASH IN THE CRIMP AREA.
- ⑧ PREPLATED .000050 MIN THK NICKEL OVER ENTIRE CONTACT WITH .000030 MIN THK GOLD ON THE MATING SURFACES, AND PLATED WITH GOLD FLASH IN THE CRIMP AREA.

⑧	1-487117-1
⑦	1-487117-0
⑥	487117-9
④	487117-8
③	487117-6
②	487117-5
①	487117-4
FINISH	PART NO

THIS DRAWING IS A CONTROLLED DOCUMENT.		DWN	G.A.MACK	8-30-83	Tyco Electronics Corporation Harrisburg, PA 17105-3608			
9-1-83		CHK	D.DOLLYHIGH	8-31-83	RECEPTACLE CONTACT, HIGH PRESSURE			
W.M. PINNISON INCHES		TOLERANCES UNLESS OTHERWISE SPECIFIED:		APVD	NAME			
0 PLC ± -		1 PLC ± -		PRODUCT SPEC	108-9024			
2 PLC ± -		3 PLC ± .005		APPLICATION SPEC	114-16015			
4 PLC ± -		ANGLES ± -		WEIGHT	-			
MATERIAL		FINISH		SIZE		CAGE CODE	DRAWING NO	RESTRICTED TO
PHOS BRONZE		SEE TABLE		A2		00779	C=487117	-
CUSTOMER DRAWING				SCALE	10:1	SHEET	1 of 1	REV
								N